

PREDADOOOR[®]

HIGH PERFORMANCE ROLLING DOOR

The Industry's Leading High-Speed, Break-Away Door.

A Product of the Year award winner, the PredaDoor roll door is the most popular high-speed door in the industry. That's because its simple, direct-drive operation and supreme reliability have enabled it to be applied successfully in a vast array of applications. The standard System 3[®] controller, with its integrated variable speed AC Drive system for soft acceleration and deceleration, makes it more dependable and durable than ever.

Plus, the PredaDoor offers the added safety and versatility of full-width replaceable window panels or optional screen panels. For general applications, it's the best value in the business.



Fast - Opens at up to 50 inches per second for improved traffic flow.

Safe - Full-width, replaceable PVC window panel (or optional screen panel) for great visibility. Standard features include reversing edge in bottom bar and two electric photo eyes.

Takes a Hit - Quick-Set[™], Break-Away[™] tabs allow bottom bar to be reset in just seconds, without tools, virtually eliminating downtime.

Minimal Space - Only 6-1/4 inches of side clearance and 3-3/4 inches of side column projection required. Fits virtually anywhere.

Wind Resistance - Integral panel connecting ribs provide resistance to wind and negative pressure. Also allows for quick, inexpensive replacement of all panel sections, if necessary. Optional rigid, 2-ply or 3-ply Rilon[™] available for high wind exterior applications.

RYTEC
CORPORATION
Driving The Door Industry.SM

PREDADOOOR[®]

HIGH PERFORMANCE ROLLING DOOR

Specifications: Subject to change

Model: Rytec[®] PredaDoor[®] Door

Standard Size: Up to 16 feet wide by 15 feet high.

Door Panel: Standard 32 ounce replaceable vinyl sections with up to four wind ribs and one full-width replaceable PVC vision panel. Options include 2-ply or 3-ply Rilon, USDA compliant material, and screen material. Consult factory for color options.

Side Frames: Fully bolt together anodized aluminum construction with full-height weatherseal to seal against panel material. Dual electric photo eyes are standard.

Bottom Bar: Quick-Set, Break-Away tabs and extruded aluminum bottom bar releases in either direction without damage to the door. Standard dual cut-off switches shut off motor when bottom bar is impacted. Pneumatic, dual-chamber reversing edge is standard. No exposed junction box on bottom bar. Vinyl loop hugs floor contour for tight seal. Bottom bar preassembled on doors at factory.

Drive System: Three-phase, variable speed AC Drive provides soft acceleration and deceleration. Independent opening and closing speeds provide flexibility to accommodate any application.

Travel Speed: Opens at up to 50 inches per second.

Electrical Controls: System 3 controller is housed in a NEMA 4 rated enclosure with factory set parameters.

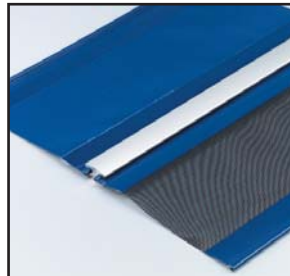
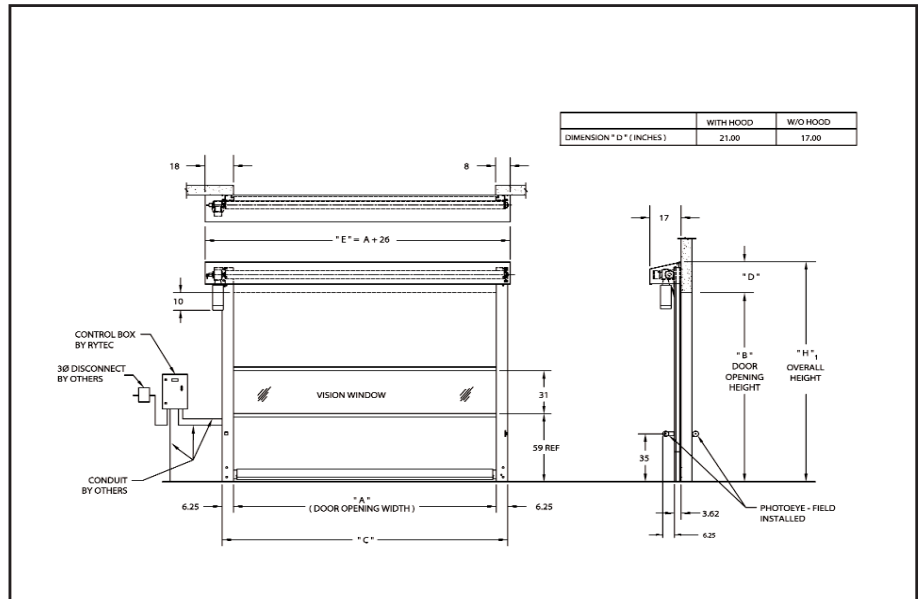

Panel Support Assembly
Integral connecting ribs allow easy replacement of individual panels, including optional screens, while providing stiff resistance against wind and negative pressure.



Easy to Reset
Quick-Set, Break-Away tabs allow bottom bar to be reset in just seconds, without tools, after taking a hit. Cut off switch between tabs deactivates motor when door is hit.



System 3 Controller
Makes programming and troubleshooting easier, more flexible and more precise than ever.

Warranty: One year limited warranty on materials and workmanship. Three year limited warranty

